

## Cooling fridge- or solarpanel inverter- area

The refrigerator in our boat is built into a cupboard in the salon. Because the salon gets quite warm on sunny days, I want to ventilate the fridge area with colder air from the tank room below.



The air in the tank room below the fridge is kept relatively cool by the (in this area) non-insulated hull. This area is also, via the air intakes (shared with the engine compartment) in open connection with the outside air.

To move the air, two 12V computer fans with a diameter of 12 cm are used. By using them in series, each at 6 V, they run more quietly and produce less noise.

To prevent the entire floor from becoming a sounding board, I cut 2 square holes of 13 x 13 cm in the floor and placed the fans, free of the wood, in the corners in rubber forks. (cut from sheet rubber)

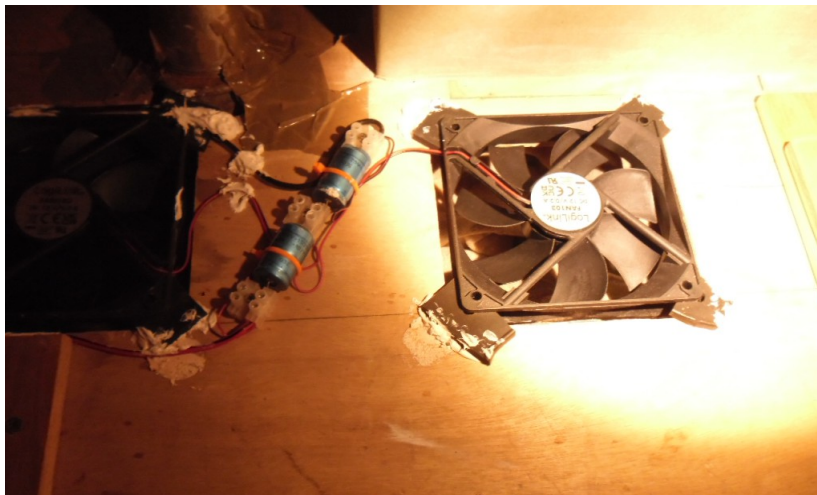

To start the 12 V fans, with only 6V, there is a capacitor parallel for both fans. The position of the openings in the floor is at the back of the refrigerator halfway underneath the cooling rack.

Because the fans are only used in warm condition, I switch them via a temperature-controlled relay.

## Sensor and relays

The **temperature controlled relay** can be adjusted/set with the 3 black push buttons. (From left to right: SET, + and -) The temperature sensor is connected at the top right with a small plug.

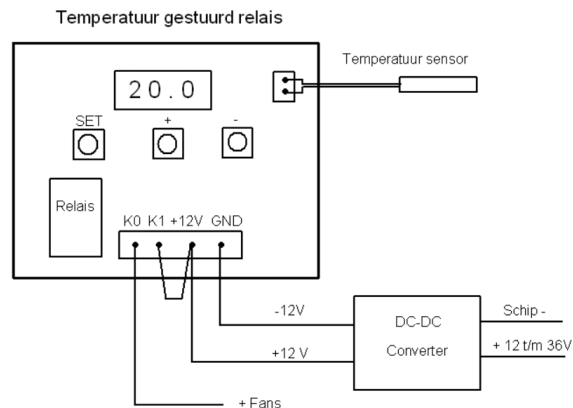
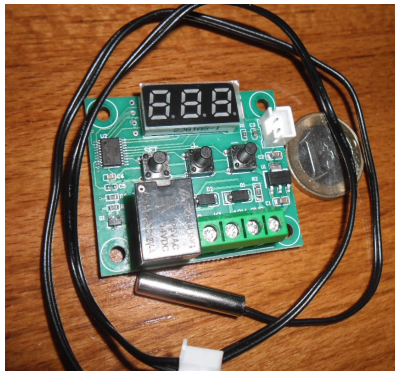

It is important that the power supply voltage does not exceed 12 V. Because this happens in practice while charging the batteries, I use a DC-DC converter that keeps the voltage at 12V. (You can also use a smaller stabilizer, but the converter was already present)

The circuit board with the relay, is (insulated) mounted on an aluminum bracket above the refrigerator. It can be read and adjusted/set there. The power supply comes from the DC-DC converter. This power supply is powered from the 12V connection on the back of the refrigerator and turned on / off with the switch on the aluminum bracket. The refrigerator itself is switched on/off on a switchboard (3.3) next to the steering position. The temperature sensor hangs high in the refrigerator room (see photo)



The principle diagram below also shows the switching method.

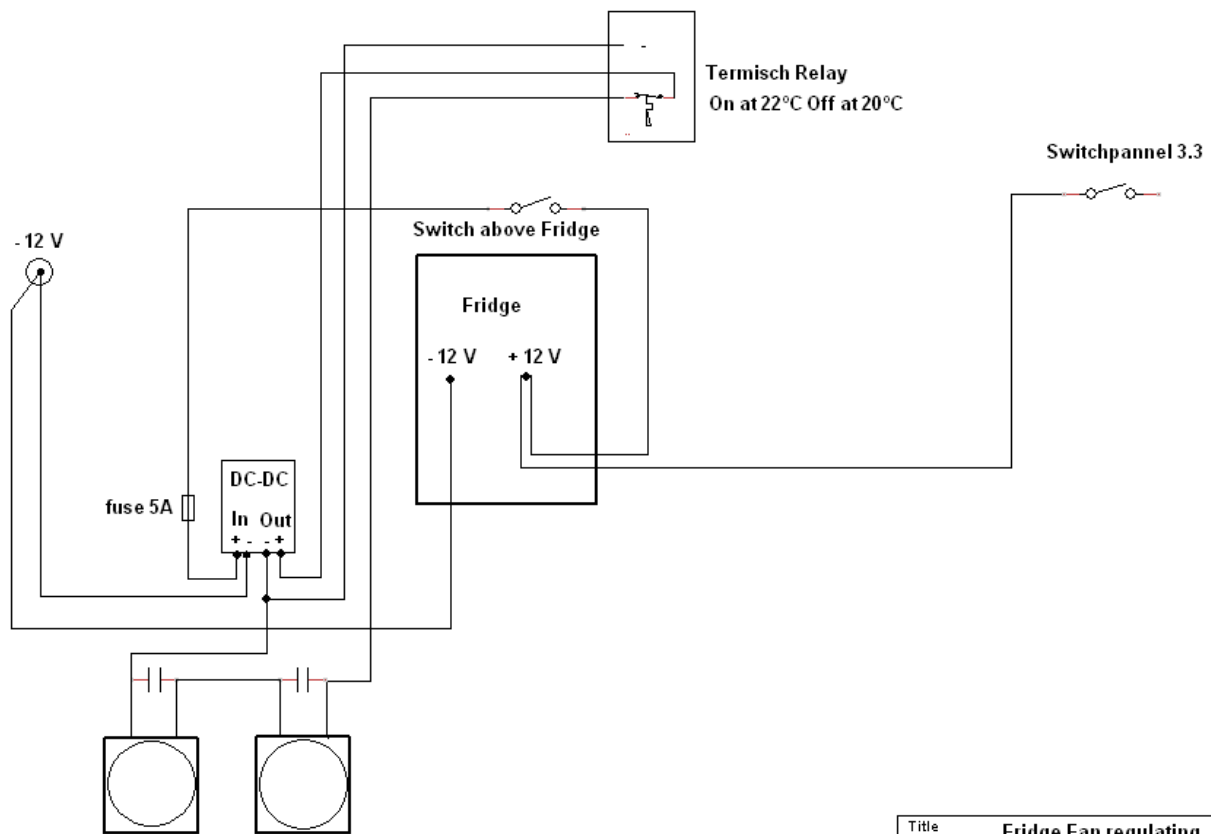

Title	Fridge Fan regulating
Author	

We are happy with this setup on board and the sound is not disturbing.

If you are considering a similar setup, it may be worthwhile to verify first that the air you are going to suck into your salon space smells clean enough. We keep our engine compartment and bilges clean and dry. However, my experience has taught me that this is not always the case in other boats.

The setup can be simplified by using only one fan and is also applicable for other purposes such as cooling a solar panel inverter at home.

You can also consider to make use of the red glow of the display to find your bearings in the dark.

### **Cooling a solar panel inverter at home.**

Our solar panel inverter at home is build in tight and doesn't have it's own fan. The charging will switch off when it gets too warm.

Cooling the inverter with an external fan when the temperature rises above 30 degrees increases our energy production.

In this case we use the same type of relay with a single fan, powered by a 6 volt adapter.

Note: Cold weather improves the output of the solar panels and will cause your inverter to produce more heath. So the extra cooling of the inverter may be needed during cold weather as well.